



T0010501-H SHOULDER PRESS WITH HAND BIKE INCLUSIVE

T0010501-H SHOULDER PRESS WITH HAND BIKE INCLUSIVE

VISTA TRIDIMENSIONALE

THREE-DIMENSIONAL VIEW

SCHEDA TECNICA (TECHNICAL DATA SHEET)

ART. T0010501-H

06-06-2024

SCALA (SCALE)

LE MISURE SONO ESPRESSE IN MM. (MEASUREMENTS ARE EXPRESSED IN MM.)



TIEGI SRL
 VIA BENEDETTO CROCE 7,
 Z.I. "CONDOTTI BARDINI",
 31058 SUSEGANA (TV),
 0438-460519

FOGLIO 1 DI 5

PIANTA (PLAN)

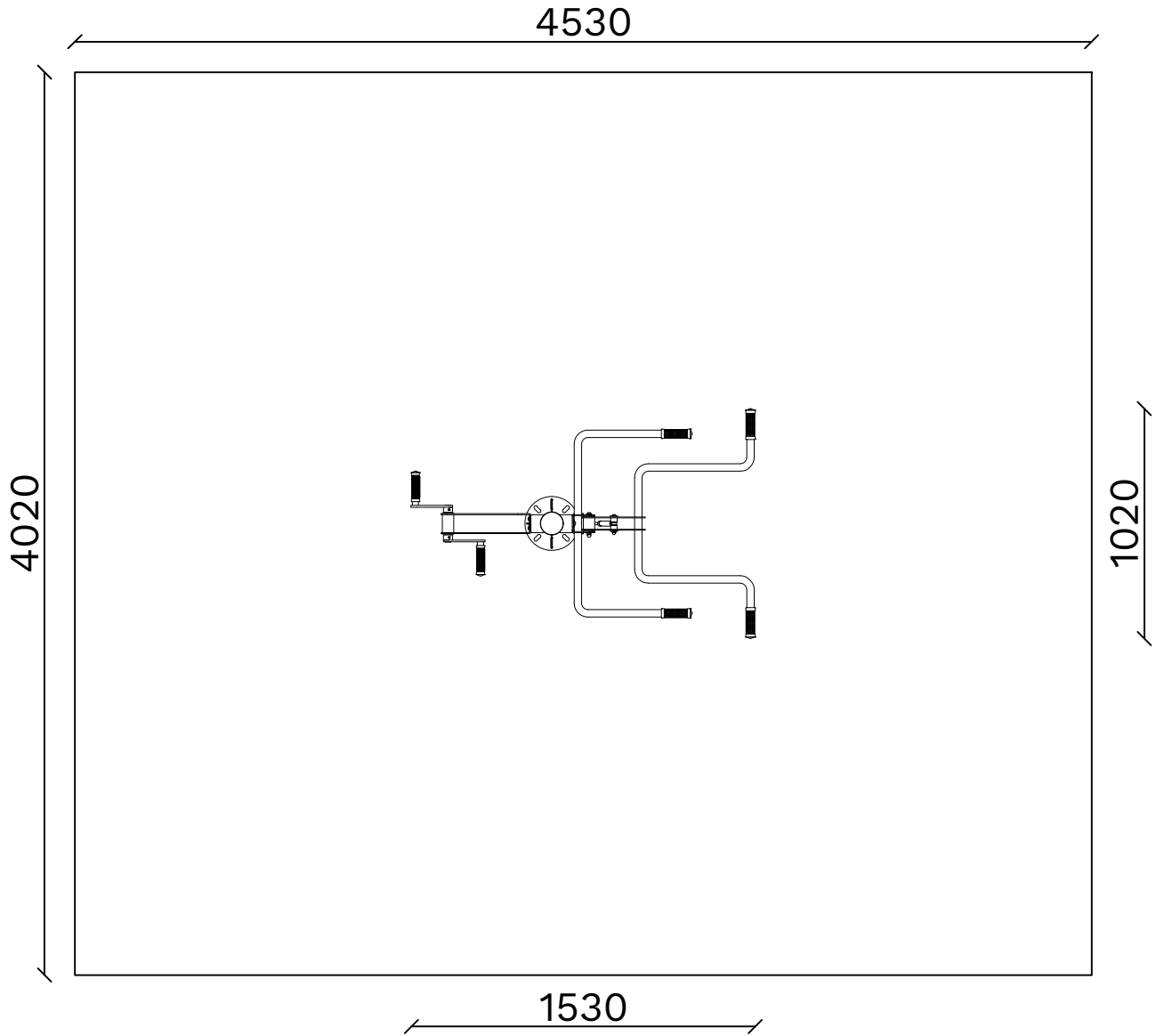

AREA DI SICUREZZA (SECURITY AREA) 18 MQ

SCHEDA TECNICA (TECHNICAL DATA SHEET)

ART. T0010501-H

06-06-2024

SCALA (SCALE) 1:20

LE MISURE SONO ESPRESSE IN MM. (MEASUREMENTS ARE EXPRESSED IN MM.)



TIEGI SRL
VIA BENEDETTO CROCE 7,
Z.I. "CONDOTTI BARDINI",
31058 SUSEGANA (TV)
0438-460519

FOGLIO 2 DI 5



ALTEZZA DI CADUTA MAX.
(MAX. FALL HEIGHT): n/a cm



INGOMBRO (OVERALL DIMENSION)
153 cm X 102 cm X 161 cm H.



NUMERO UTILIZZATORI 2
(MAX N. OF SIMULTANEOUS USERS)



AREA DI SICUREZZA (SECURITY AREA)
453 cm X 402 cm



SUP. ANTITRAUMA CONSIGLIATA
(RECOMMENDED SAFETY SURFACING AREA)
18 MQ.



ALTEZZA D'USO (USE HEIGHT)
>140 cm

SCHEDA TECNICA (TECHNICAL DATA SHEET)

ART. T0010501-H

06-06-2024

SCALA (SCALE)

LE MISURE SONO ESPRESSE IN MM. (MEASUREMENTS ARE EXPRESSED IN MM.)



TIEGI SRL
VIA BENEDETTO CROCE 7,
Z.I. "CONDOTTI BARDINI",
31058 SUSEGANA (TV)
0438-460519

FOGLIO 3 DI 5

MANOPOLE ZIGRINATE
(*KNURLED HANDLES*)



L'ATTREZZO È PROVVISORIO DI QR CODE PER LA VISIONE DI VIDEO ESPLICATIVO D'USO (*THE EQUIPMENT IS PROVIDED WITH A QR CODE, DISPLAYING AN EXPLANATORY VIDEO OF THE EXERCISE*)

TUBI IN METALLO CURVATI. PROCESSO DI VERNICIATURA PER CATAFORESI, PRIMER E VERNICIATURA TERMOINDURENTE 180°C

(*CURVED METAL TUBES. CATAPHORESIS, PRIMER AND 180°C THERMOSETTING PAINTING PROCESS APPLIED*)



PIASTRE IN METALLO CON PROCESSO DI VERNICIATURA DI CATAFORESI, PRIMER E VERNICIATURA TERMOINDURENTE 180°C
(*METAL PLATES WITH CATAPHORESIS, PRIMER AND 180°C THERMOSETTING PAINTING PROCESS APPLIED*)

TUTTI GLI ELEMENTI DI FISSAGGIO, VITI, DADI, RONDELLE ECC. SONO IN ACCIAIO INOX

(*ALL FASTENERS, SCREWS, NUTS, WASHERS, ETC. ARE MADE OF STAINLESS STEEL*)

SCHEMA TECNICA (*TECHNICAL DATA SHEET*)

ART. T0010501-H

06-06-2024

SCALA (*SCALE*)

LE MISURE SONO ESPRESSE IN MM. (*MEASUREMENTS ARE EXPRESSED IN MM.*)



TIEGI SRL
VIA BENEDETTO CROCE 7,
Z.I. "CONDOTTI BARDINI",
31058 SUSEGANA (TV)
0438-460519

FOGLIO 4 DI 5

VISTA FRONTALE
(FRONTAL VIEW)

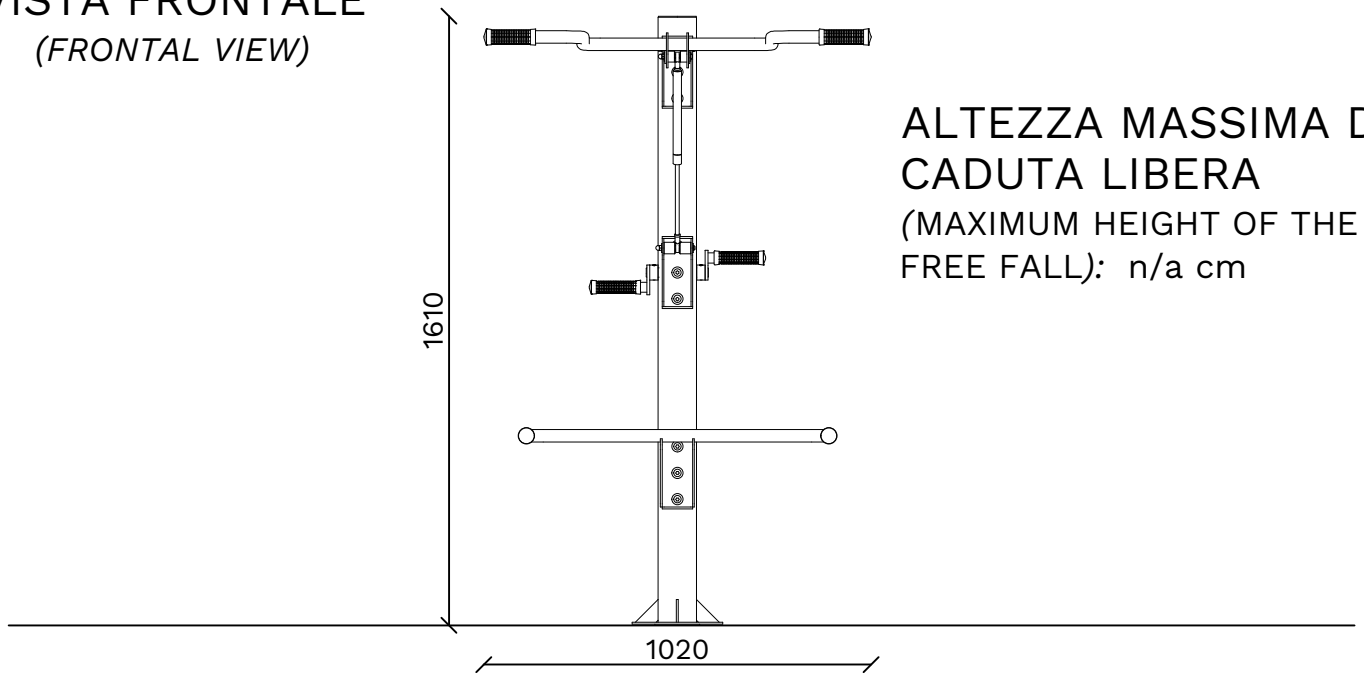

ALTEZZA MASSIMA DI
CADUTA LIBERA
(MAXIMUM HEIGHT OF THE
FREE FALL): n/a cm

VISTA LATERALE
(LATERAL VIEW)

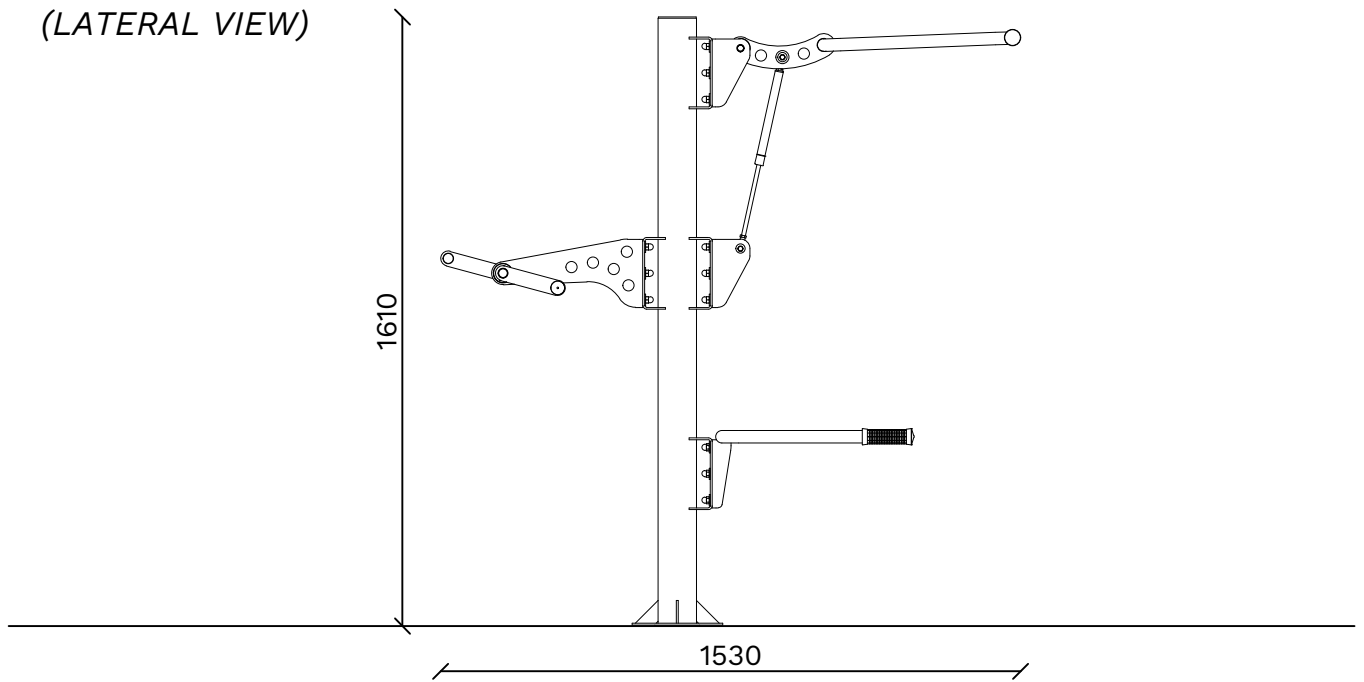

INGOMBRO MAX (OVERALL DIMENSIONS)

SCHEDA TECNICA (TECHNICAL DATA SHEET)

ART. T0010501-H

06-06-2024

SCALA (SCALE) 1:20

LE MISURE SONO ESPRESSE IN MM. (MEASUREMENTS ARE EXPRESSED IN MM.)



TIEGI SRL
VIA BENEDETTO CROCE 7,
Z.I. "CONDOTTI BARDINI",
31058 SUSEGANA (TV)
0438-460519

FOGLIO 5 DI 5